



MULTI FIT TRUCK TOWBAR

INSTALLATION INSTRUCTIONS

PART NUMBER

03544R

VEHICLE APPLICATION

MULTI FIT TRUCK BAR

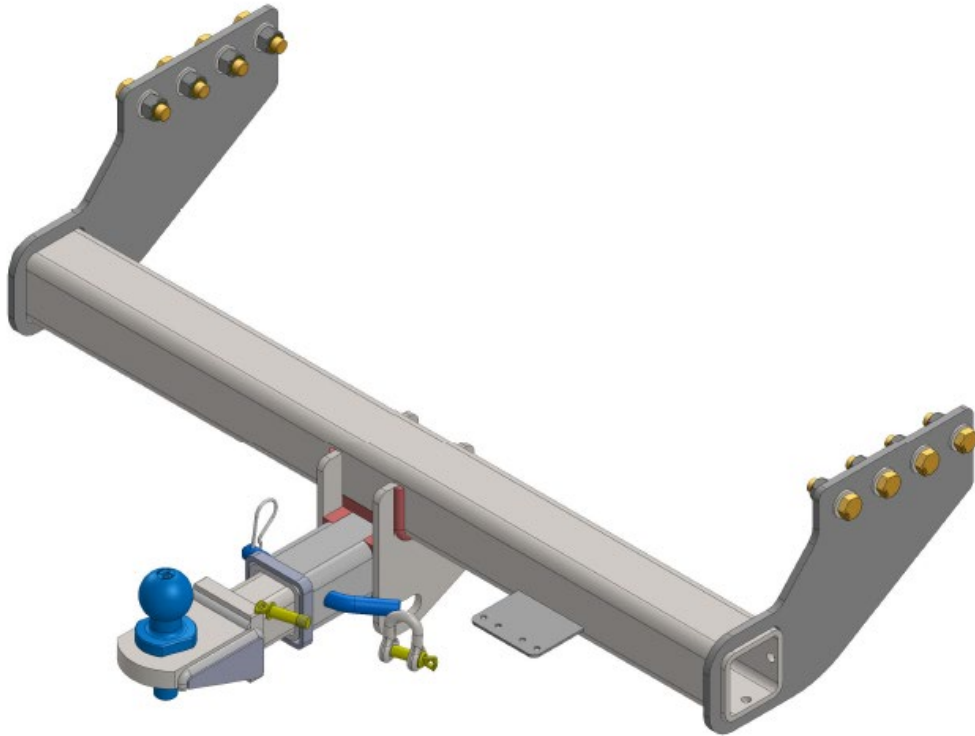

PRODUCT DETAILS:

Part Number:	03544R	Maximum Towing Braked:	2800	kg*
ECU Number:	N/A	Maximum Towing Unbraked:	750	kg
Tail Harness Length Required:	N/A	Maximum Static Ball Load:	280	kg*

***NOTE:** maximum rating may lower if GVM is over 5,000kg - refer to VSB6/VSG16

FITTING DETAILS:

Towbar Installation Time:	180 Mins.	Vehicle Coding Required:	NO
Wiring Installation Time:	N/A	RPA Disable/Other:	NO
Total Installation Time:	180 Mins		

CAUTION: IF THIS TOWBAR IS BEING FITTED TO A TRUCK FITTED WITH A TIPPER BODY, CARE SHOULD BE TAKEN TO ENSURE THERE IS SUFFICIENT CLEARANCE DURING TIPPING.



MULTI FIT TRUCK TOWBAR

INSTALLATION INSTRUCTIONS

PART NUMBER

03544R

VEHICLE APPLICATION

MULTI FIT TRUCK BAR

ENSURE THAT INSTRUCTIONS ARE UNDERSTOOD PRIOR TO FITMENT.

i BEFORE YOU START:

Hayman Reese recommends that instructions are read completely prior to fitment.



Compliance and Legal Requirements

It is important to ensure that the fitting of this towbar is signed off after fitment by an approved person.

For Light vehicles under 4500kg GVM, this will depend upon the state or territory in which the vehicle is registered and falls under local State and Territory legislation.

For vehicles over 4500kg GVM, the requirements of the National Heavy Vehicle Regulator will normally apply, although WA is not currently working within this scheme, as at time of release. Please consult your local transport authority (or NHVR) for guidance on this matter.

If Truck GVM is over 5000kg ensure that the additional labelling requirements of VSG 16 are met. This legislation covers the de-rating of the 50mm towball and associated couplings for vehicles over 5000kg GVM. Hayman Reese have a range of labels to ensure compliance with VSG16 – contact Hayman Reese for further information.

There is a requirement under AS4177 for the height of a **50mm towball** to meet the requirements for ADR 62/02. This height measured from the ground to the centre of the towball is 350mm to 460mm when the vehicle is fully laden to GVM. Refer to detailed guidance specified below.

It is also important to understand the customer expectations regarding ball height and matching this whilst ensuring compliance to AS4177 and ADR 62/02.

Drilling

- For any required drilling during installation, ensure that the area is clear of fuel, electrical & other components that may be damaged.
- All holes drilled into the chassis shall have all burrs & swarf removed then coated with a suitable rust preventative paint.

Bolts/Fasteners

- Ensure that all hardware is fastened to correct torque as specified in this fitting instruction.
- All fasteners supplied with this product are used to achieve a specified clamp loading. If replacement is required ensure that fasteners of the same grade and class are used.

NOTE: Achieving correct torque is critical to proper installation and responsibility of the installer. Towbar failures attributed to tension issues from over tightening or under tightening are not covered by Hayman Reese warranty.

Product Labels

One Towbar compliance label is provided with this product and shall be conspicuously located on rear face of the cross tube after welding.

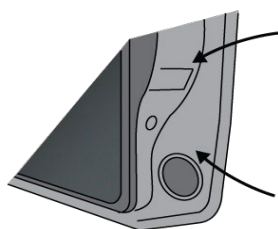

Place **Load Rating** sticker inside driver's door here



MULTI FIT TRUCK TOWBAR

INSTALLATION INSTRUCTIONS

PART NUMBER

03544R

VEHICLE APPLICATION

MULTI FIT TRUCK BAR

⚠ WARNING:

FOR TOWING PURPOSES ONLY - This towbar is designed and tested by Hayman Reese to adhere to ADR 62/02 which provides only for the expected load demands of towing.

50mm TOWBALL application

In all applications where a 50mm towball is used for towing, certain Australian Design Rules (ADR) regulations must be met. **Australian Standard 4177.1** states:

When towbar and towball are fitted to the laden towing vehicle, the height of the towball above ground shall be between 350mm and 460mm (or capable of being adjusted)

Prior to purchasing, it is important to ensure that the ball height from the ground will be compliant with ADR 62. Please refer to the below figure to help calculate your expected ball height.

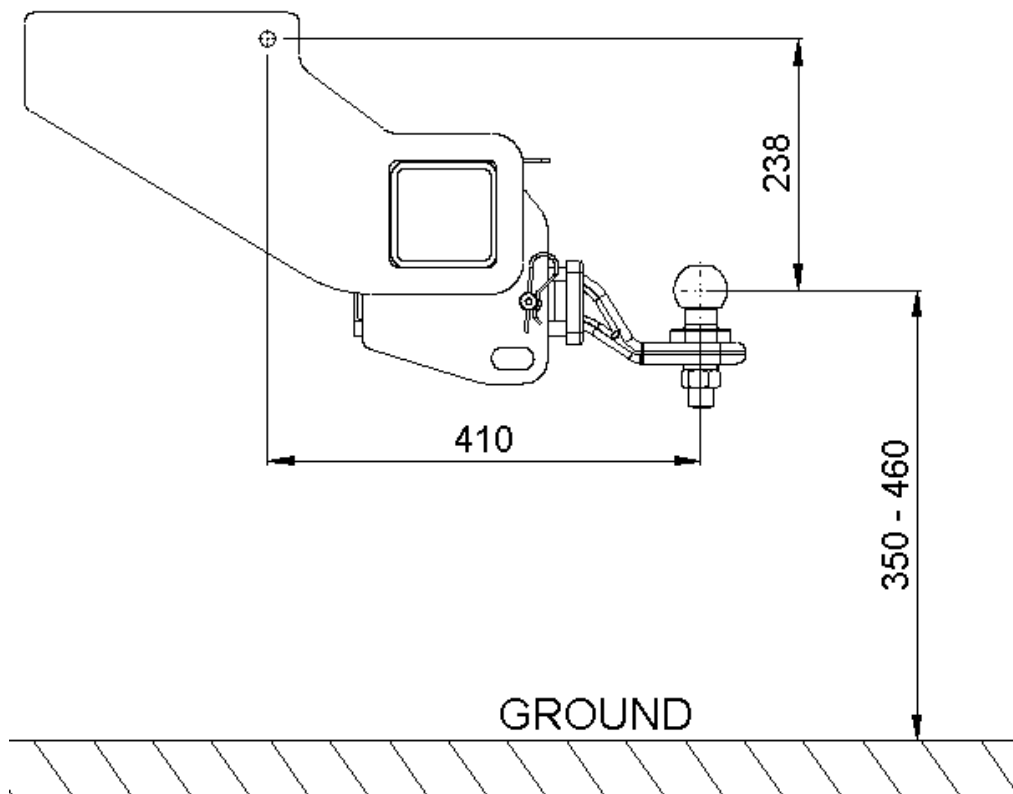



MULTI FIT TRUCK TOWBAR

INSTALLATION INSTRUCTIONS

PART NUMBER

03544R

VEHICLE APPLICATION

MULTI FIT TRUCK BAR

TOWBAR ASSEMBLY DIAGRAM

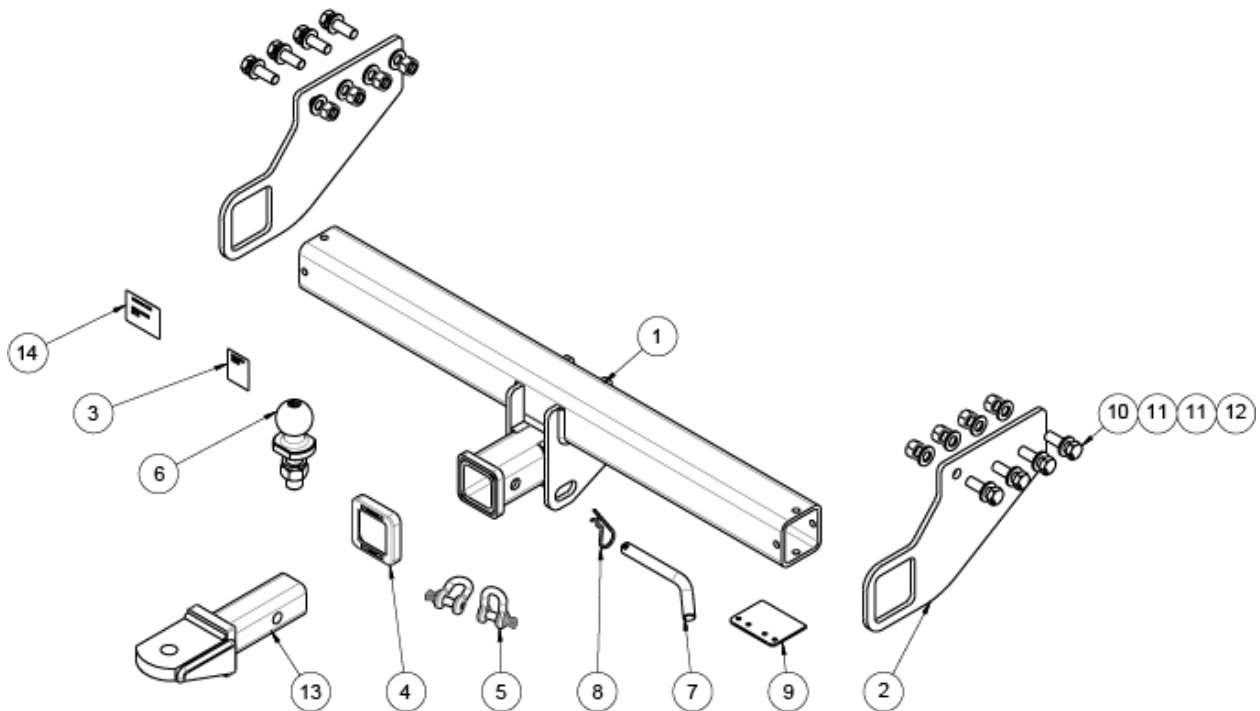

ITEM NO.	DESCRIPTION	QTY
1	MULTI FIT TOWBAR 2800KG	1
2	SIDE ARM	2
3	HAYMAN REESE LOGO STICKER	1
4	HITCH BOX COLLAR COVER	1
5	D-SHACKLE 10mm	2
6	TOWBALL 50mm	1
7	PULL PIN	1
8	R CLIP	1
9	WIRE LOOM BRACKET	1
10	SCREW HEX HD M14x45x1.5P G10.9	8
11	WASHER PLAIN M14x28x3.0mm	16
12	NUT NYLOC HEX HD M14x1.5P G10	8
13	TRAILER BALL MOUNT	1
14	COMPLIANCE LABEL	1



MULTI FIT TRUCK TOWBAR

INSTALLATION INSTRUCTIONS

PART NUMBER

03544R

VEHICLE APPLICATION

MULTI FIT TRUCK BAR

PRE- FITTING GUIDANCE

Select a pre-existing hole in the chassis ensuring that the hole is at least 60mm away from the end of the chassis. Drill out to M14 clearance if required.

Bolt up the sidearm to the chassis with one of the M14 fasteners.

Repeat on the other chassis member being careful to ensure the selected hole is the same both sides. Also ensure that the top surface of the side arms are parallel to the top surface of the chassis.

Insert drawbar and assess the ball height for compliance with ADR 62/02. Refer to page 3 for more information.

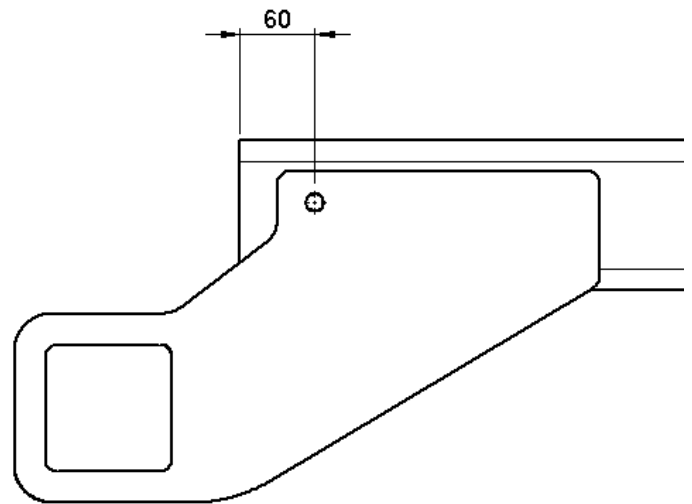

1. Select 3x existing holes or drill 3x holes in the chassis.

Position the holes (minimum) 50mm apart between hole centres.

Mark and Drill 3x holes in the side arm to suite.

Repeat for the opposite side.

NOTE:

Avoid drilling holes in the chassis close to existing holes. It is better to oversize existing holes where possible.

The holes can be in a straight line, but it is desirable to have the holes also spaced vertically across two rows if possible.

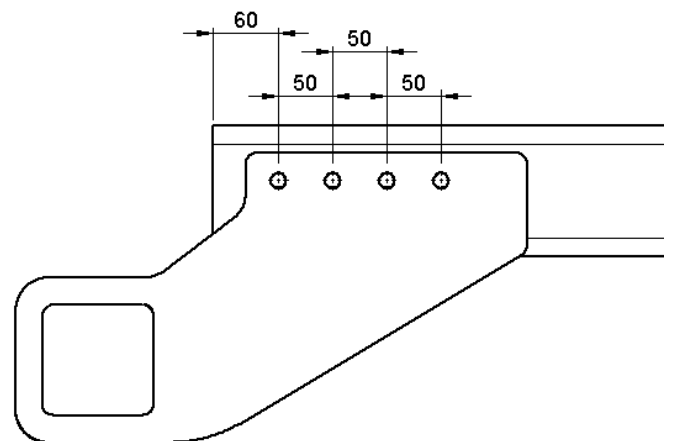



MULTI FIT TRUCK TOWBAR

INSTALLATION INSTRUCTIONS

PART NUMBER

03544R

VEHICLE APPLICATION

MULTI FIT TRUCK BAR

2. Fit the side arm to chassis and secure it with 4 bolts, 8 washers and 4 nuts.

Repeat for the other side.

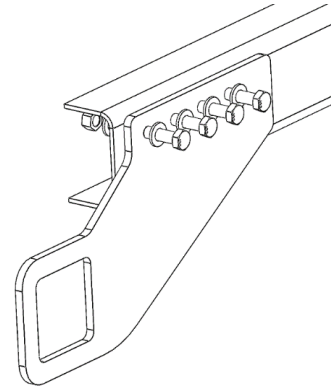

3. Fit the cross tube between to the side arms.

Torque:

M14x1.5 – 10.9 = 196Nm

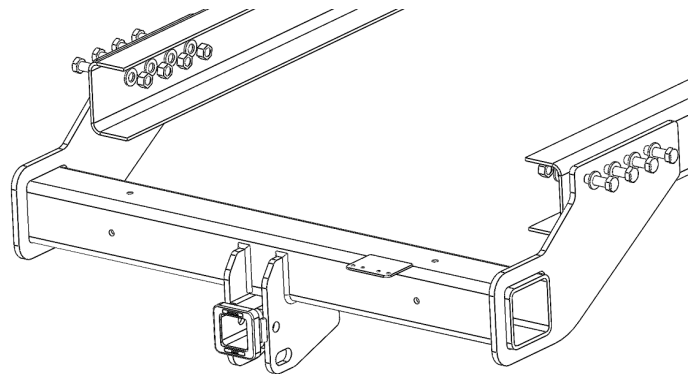

4. Adjust and centralise the cross tube between the two sidearms so the protrusion both ends is equal.

Add a 6mm weld all around the cross tube and side arm.

Repeat for the other side plate.

Note:

A minimum distance of 25mm from the end of tube to the face of the side arm if welded externally.

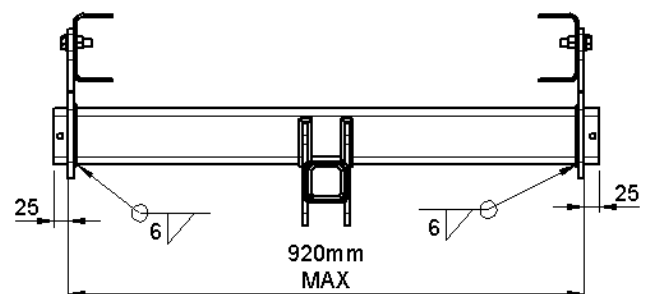



MULTI FIT TRUCK TOWBAR

INSTALLATION INSTRUCTIONS

PART NUMBER

03544R

VEHICLE APPLICATION

MULTI FIT TRUCK BAR

5. Locate the plug plate 150mm from the dropper face. Add 3mm x 15mm welds to plate.
6. Spray cold galvanized paint on all the welds to prevent corrosion
7. Spray paint the whole tow bar.

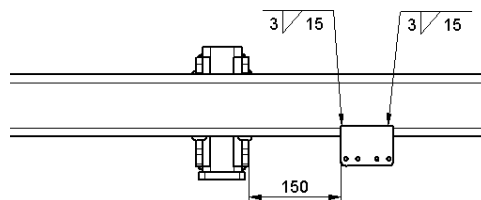



CUSTOMER INFORMATION

PLACE THESE INSTRUCTIONS IN THE
VEHICLE'S GLOVEBOX AFTER INSTALLATION

**THANK YOU FOR PURCHASING HAYMAN REESE.
WITH CORRECT MAINTENANCE AND CARE THIS PRODUCT WILL PROVIDE A
LIFETIME OF TROUBLE-FREE OPERATION.**

i TOWBAR MAINTENANCE AND CARE:

1. Hayman Reese recommends routine inspection of your towbar to ensure trouble free towing.
 - Bolt security and tension should be regularly inspected and checked for correct tension. Replace any worn or defective parts with suitable grade & class fasteners. Inspection should be requested to coincide with vehicle major services.
2. Hayman Reese recommends routine inspection of your towbar to ensure trouble free towing.
 - Bolt security and tension should be regularly inspected and checked for correct tension. Replace any worn or defective parts with suitable grade & class fasteners. Inspection should be requested to coincide with vehicle major services.
3. It is the owner's responsibility to ensure towing and down ball weight capacities of the towing vehicle are not exceeded.
 - Towing and down ball weights allowable may differ according to model variations. Please refer to owner's manual or vehicle dealer to confirm exact rating for your vehicle model variant.
 - It is not uncommon for the vehicle tow rating to differ from the towbar rating. When this occurs, the lesser rating must be adhered to.
 - For vehicles fitted with enhanced vehicle functions that may be altered/changed when towing i.e Trailer sway mitigation, blind spot detection, adaptive cruise control etc. Please consult owner's manual to understand changes enabled when towing and after towing.

i WARRANTY INFORMATION:

Hayman Reese Towbars are covered by a Lifetime Warranty.

Our goods come with guarantees that cannot be excluded under the Australian Consumer Law. You are entitled to a replacement or refund for a major failure and for compensation for any other reasonably foreseeable loss or damage. You are also entitled to have the goods repaired or replaced if the goods fail to be of acceptable quality and the failure does not amount to a major failure.

For further details please visit www.haymanreese.com.au/warranty or contact customer service on 1800 812 017 or info@haymanreese.com.au.



CUSTOMER INFORMATION

PLACE THESE INSTRUCTIONS IN THE VEHICLE'S GLOVEBOX AFTER INSTALLATION

TOWBALL MOUNT



- Before towing, ensure R-Clip is properly installed.
- Regularly inspect for wear. Replacement parts are available from your Hayman Reese Distributor.

REMOVAL/INSTALLATION

STEP 1

Insert Trailer Ball Mount (TBM) into towbar hitch box, aligning hole in TBM shank with hole in hitch box.

STEP 2

Insert the pull Pin through hole in hitch box and hole in TBM shank. Insert the R-clip into the Pull Pin hole to lock it place.

STEP 3

Install tow ball onto TBM and tighten as follow.

TORQUE:

50mm ball to 350 Nm

70mm ball to 750 Nm

